

# Automatic Reversible Cam Action Workholding Assemblies

Reversible Cam Action Workholding Assembly

AUTOMATICALLY RELEASES AND RETRACTS CLAMP STRAP

## AUTOMATIC REVERSIBLE ROLLER CAM ACTION ASSEMBLIES

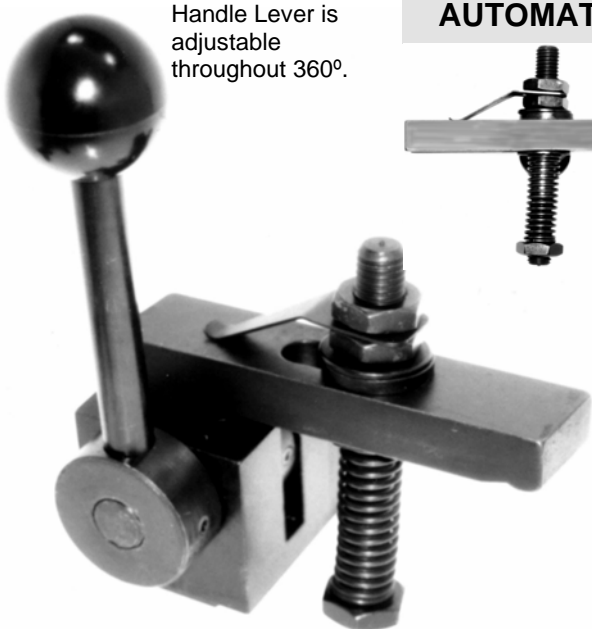

Handle Lever is adjustable throughout 360°.



Handle may be mounted on either side of base.

Optional Spherical Flange Nut and Spherical Washer allowing greater 'N' length adjustment for work piece variations.



Handle with SPHERICAL WASHER

All parts are standard, replaceable and available. Add 'F' to Part No. for Flange Nut Style.

Handle with FLANGE NUT

This Automatic Reversible Roller Cam Assembly can with one quick motion move in and down on the work piece. It can then release and withdraw freely with its cam action. The mounting block is secured by two screws in its base installation.

TOP VIEW WITH HANDLE DRAWING FOR FLANGE NUT STYLE

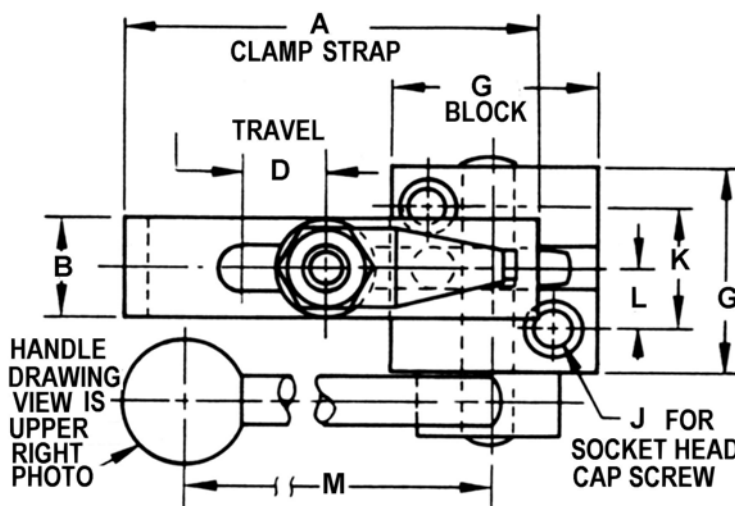

BOTTOM VIEW SPHERICAL WASHER STYLE

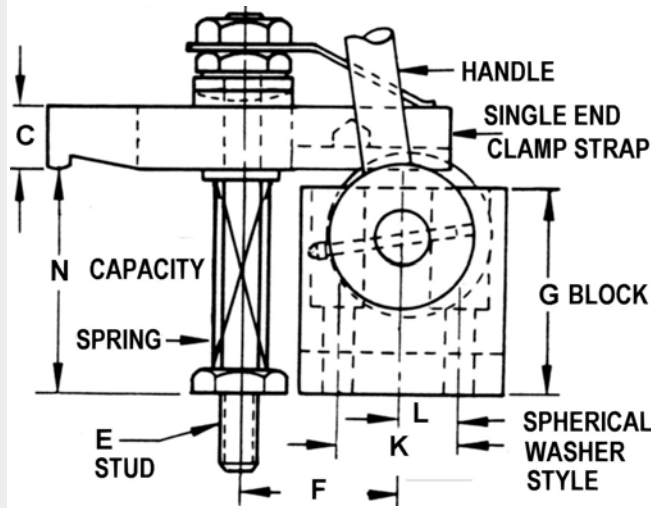

All machinery parts are manufactured from steel and hardened. Black Oxide finish per Mil-Spec CB 924A

PART NO. Add 'F' for Flange Nut	A Strap Length	B Strap Width	C Strap Height	D Travel	E Stud	F Centers Block/Stud	G Block Squared	J Socket Hd Cap Screw	K Cap Screw Loc.	L from Centers	M Handle Length	N Capacity
UDB-921400	2-1/2	5/8	3/8	1/2	1/4-20 x 2-7/8	1-1/32	1-1/4	#10	3/4	3/8	3"	1-3/8
UDB-921405	4-1/2	1-1/2	3/4	1"	5/8-11 x 5-3/4	2-1/16	2-1/2	5/16	1-1/2	3/4	6"	2-5/8
UDB-921410	5-1/2	1-1/2	3/4	1"	5/8-11 x 5-3/4	2-1/16	2-1/2	5/16	1-1/2	3/4	6"	2-5/8
UDB-921415	6"	1-1/2	3/4	1"	5/8-11 x 5-3/4	2-1/16	2-1/2	5/16	1-1/2	3/4	6"	2-5/8

# Clamp Assembly Components

# Get A Hold With UNITED Components

## DOUBLE CAM

Heat Treated Black Oxide Finish. Balanced Strong Action.  
**Use with single and double end center cam assemblies.**  
 For matching Eye Bolts, refer to Clamp Assemblies.

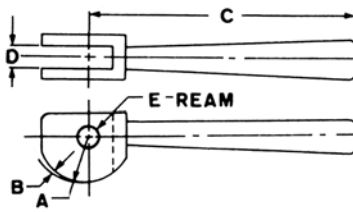

DOUBLE CAM	A	B	C	D	E
UDB-949005	9/16	1/16	2-1/2	1/4	3/16
UDB-949010	11/16	1/16	3-1/2	5/16	1/4
UDB-949012	3/4	3/32	4"	3/8	5/16
UDB-949015	15/16	7/64	5"	1/2	3/8
UDB-949020	1-3/16	9/64	5-3/8	5/8	5/8

## SINGLE CAM

Heat Treated Black Oxide Finish  
**Use on End Cam Clamp Assemblies.**  
 For matching End Clamp Straps, refer to Clamp Assemblies.

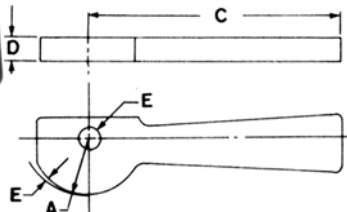

SINGLE CAM	A	B	C	D	E
UDB-949040	7/16	1/16	1-7/8	3/16	5/32
UDB-949045	5/8	1/16	2-3/4	1/4	1/4
UDB-949050	7/8	7/64	3-3/4	3/8	5/16
UDB-949055	1-1/16	9/64	4"	1/2	3/8

## CLAMP REST

Use with single end clamp assemblies.  
 For matching single end clamp straps, refer to Clamp Assemblies.



Heat Treated Black Oxide Finish

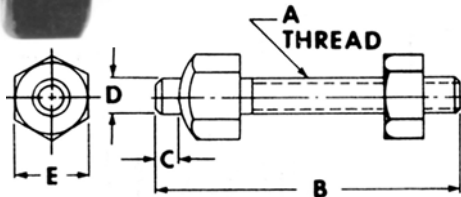

PART NO.	A	B	C	D	E
UDB-932200	1/4-20	1-1/4	1/8	5/32	7/16
UDB-932205	5/16-18	1-7/8	11/64	7/32	1/2
UDB-932210	5/16-18	3-1/4	11/64	7/32	1/2
UDB-932220	3/8-16	2-1/4	7/32	11/32	9/16
UDB-932225	3/8-16	3-7/8	7/32	11/32	9/16
UDB-932230	1/2-13	2-3/8	1/4	11/32	11/16
UDB-932235	1/2-13	3-7/8	1/4	11/32	11/16
UDB-932240	5/8-11	2-5/8	1/4	15/32	7/8
UDB-932245	5/8-11	3-7/8	1/4	15/32	7/8
UDB-932250	3/4-10	2-3/4	1/4	15/32	1-1/16
UDB-932255	3/4-10	3-7/8	1/4	15/32	1-1/16

## CLAMP REST PLATE

Heat Treated Black Oxide Finish

Use with end clamp or hand knob assemblies. Ready to install.

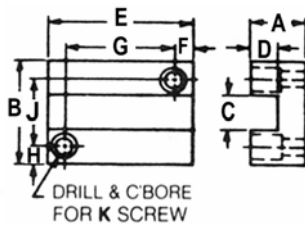
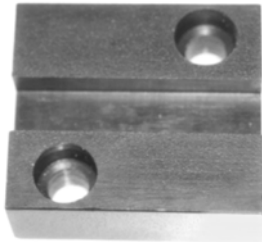

PART NO.	A	B	C	D	E	F	G	H	J	K	FITS STUD
UDB-946570	5/16	3/4	3/16	3/32	3/4	5/32	7/16	5/32	7/16	#5	#6-32, M4
UDB-946573	1/2	1"	1/4	3/16	1-1/2	7/16	5/8	3/16	5/8	#10	#10-32, M5
UDB-946576	1/2	1-1/2	5/16	3/16	1-7/8	7/16	1"	1/4	1"	1/4	1/4-20, M6
UDB-946579	1/2	1-1/2	5/16	3/16	2-3/8	7/16	1"	1/4	1"	1/4	1/4-20, M6
UDB-946582	1/2	1-1/2	3/8	1/4	1-7/8	7/16	1"	1/4	1"	1/4	5/16-18, M7-M8
UDB-946585	1/2	1-1/2	1/2	1/4	1-7/8	7/16	1"	1/4	1"	1/4	3/8-16, M8-M10
UDB-946587	5/8	1-3/4	1/2	1/4	2"	7/16	1-1/8	5/16	1-1/8	1/4	3/8-16, 1/2-13

## CLAMP SPRING

Use with strap clamp



UNITED PART NO.	ID Fits Stud Size	Free Length Nominal
UDB-936005	1/4	5/8
UDB-936007	5/16	5/8
UDB-936010	5/16	1-1/2
UDB-936015	3/8	1-1/2
UDB-936020	1/2	1-1/2
UDB-936025	5/8	1-9/16
UDB-936030	3/4	1-3/4

# Clamp Straps to Hold Your Fixture

## Clamp Straps with Radius Noses

PART NO.	A	B	C	D	E	F	G	H
UDB-948400 UDB-948405	9/32	3/8	5/8	2 2-1/2	1 1-1/8	1/2	3/16	1/8
UDB-948410 UDB-948415 UDB-948420	11/32	1/2	1	2-3/4 3-1/4 3-3/4	1-1/2	7/16 13/16 1-3/16	1/4	3/16
UDB-948425 UDB-948430 UDB-948435 UDB-948440	13/32	5/8	1-1/4	3 4 5 6	1-11/16 2-3/16 2-11/16 3-1/16	3/4 1 1-1/2 2	3/8	9/32
UDB-948445 UDB-948450 UDB-948455 UDB-948460 UDB-948465	17/32	5/8	1-1/4	4 4-1/2 5 5-1/2 6	2-1/4	1 1-1/2	3/8	9/32
UDB-948470 UDB-948475 UDB-948480 UDB-948485	21/32	7/8	1-1/2	4-1/2 5 5-1/2 6	2-1/2	1 1-1/2	1/2	9/32
UDB-948520 UDB-948525 UDB-948530 UDB-948535	25/32	1	1-3/4	6 6-1/2 7 7-1/2	3-1/4	1-3/4	1/2	5/16

### SINGLE END CLAMP STRAP

Heel Rest  
Clamp with  
Finger Grips  
used in  
Clamp  
Assemblies.



SLOTTED  
HEEL

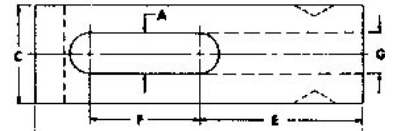

RADIUS  
NOSE

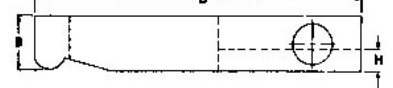

PART NO.	A	B	C	D	E	F
UDB-948620 UDB-948625 UDB-948630 UDB-948635	13/32	5/8	1-1/4	3 4 5 6	1 1-1/2 2 2-1/2	1
UDB-948640 UDB-948645 UDB-948650 UDB-948655 UDB-948660	17/32	5/8	1-1/4	4 4-1/2 5 5-1/2 6	1-1/2 1-3/4 2 2-1/4 2-1/2	1
UDB-948665 UDB-948670 UDB-948675 UDB-948680	21/32	3/4	1-1/2	4-1/2 5 5-1/2 6	1-5/8 1-7/8 2-1/8 2-3/8	1-1/4
UDB-948710 UDB-948715 UDB-948720 UDB-948725	25/32	1	1-3/4	6 6-1/2 7 7-1/2	2-1/8 2-3/8 2-5/8 2-7/8	1-3/4

### DOUBLE END CLAMP STRAP

For clamping flat  
pieces.

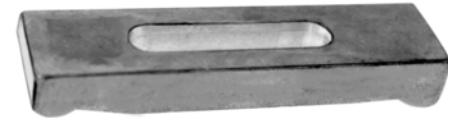

You can invert  
and use for  
round pieces in  
V-Block.

Used on Double  
End Strap Clamp  
Assemblies.

DOUBLE  
RADIUS  
NOSE

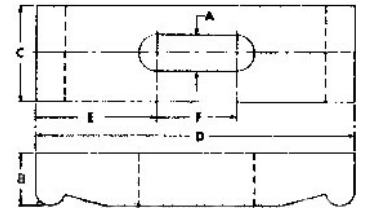

CENTER CLAMP

PART NO.	A	B	C	D	E	F	G	H
UDB-948005 UDB-948010	9/32	3/8	5/8	2 2-1/2	1 1-1/8	1/2	7/32	1/4-20
UDB-948015 UDB-948020 UDB-948025	11/32	1/2	1	2-3/4 3-1/4 3-3/4	1-1/2	7/16 13/16 1-3/16	9/32	5/16-18
UDB-948030 UDB-948035 UDB-948040 UDB-948045	13/32	5/8	1-1/4	3 4 5 6	1-11/16 2-3/16 2-11/16 3-1/16	3/4 1 1-1/2 2	5/16	3/8-16
UDB-948050 UDB-948055 UDB-948060 UDB-948065 UDB-948070	17/32	5/8	1-1/4	4 4-1/2 5 5-1/2 6	2-1/4	1 1-1/2	7/16	1/2-13
UDB-948075 UDB-948080 UDB-948085 UDB-948090	21/32	7/8	1-1/2	4-1/2 5 5-1/2 6	2-1/2	1 1-1/2	1/2	5/8-11

### TAPPED END CLAMP STRAP

RADIUS  
NOSE

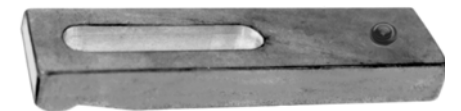

Use with End Hand  
Knob Clamping  
Assemblies.  
A Tapped Heel  
Strap.

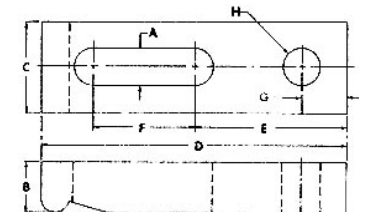

Class 2B Threads.

PART NO.	A	B	C	D	E	F	G	H	J
UDB-948205 UDB-948210	9/32	3/8	5/8	2 2-1/2	1 1-1/8	1/2	5/32	3/16	3/16
UDB-948215 UDB-948220 UDB-948225	11/32	1/2	1	2-3/4 3-1/4 3-3/4	1-1/2	7/16 13/16 1-3/16	1/4	1/4	1/4
UDB-948230 UDB-948235 UDB-948240 UDB-948245 UDB-948250	17/32	5/8	1-1/4	4 4-1/2 5 5-1/2 6	2-1/4	1	5/16	5/16	3/8
UDB-948255 UDB-948260 UDB-948265 UDB-948270	21/32	3/4	1-1/2	4-1/2 5 5-1/2 6	2-1/2	1 1-3/8	3/8	3/8	1/2

### END CAM CLAMP STRAP

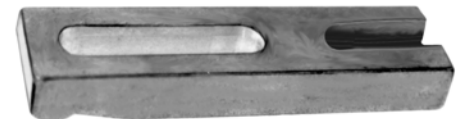

Slotted Heel Strap  
used in  
End Clamp  
Assemblies.

RADIUS  
NOSE

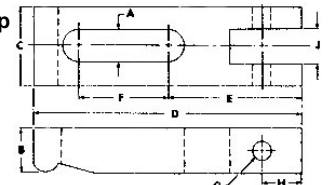

# Double End Clamp Assemblies

# Instant Double End Clamping Assemblies

## DOUBLE END ACORN NUT CENTER CLAMPS

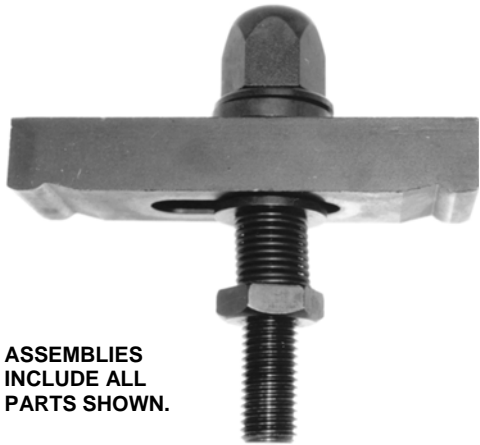

ASSEMBLIES INCLUDE ALL PARTS SHOWN.

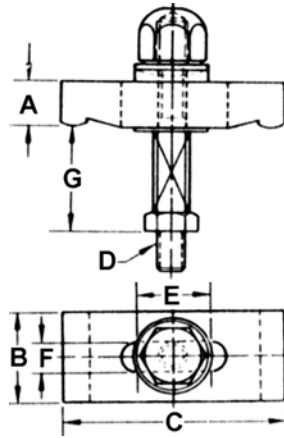

ACORN NUT protects stud while clamp holds from either side. The Spherical Washers permit clamping of uneven work piece. Spring loaded stud offers instant release.

### UNITED ADVANTAGES and FEATURES:

- Double End Clamp Assemblies used for flat work or inverted to hold round work pieces in the V-groove.
- Provides simultaneous clamping of two parts.
- Clamps rotate freely for easy part removal.
- All parts interchangeable.
- Components may be added.
- Add Nylon Cap when clamping soft materials.
- Stable clamping on milling, boring & drilling machines.
- Quick sure set-ups on short runs.
- See next page for more.

## DOUBLE END HAND KNOB CENTER CLAMPS



ASSEMBLIES INCLUDE ALL PARTS SHOWN.

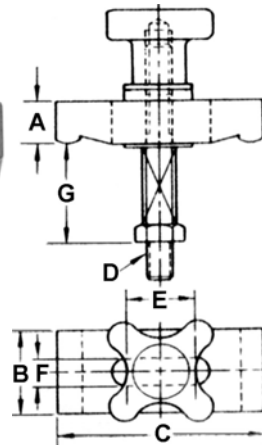

HAND KNOB tightens two work surfaces at one time. Spring loaded stud instantly releases work pieces. Spherical Washers permit clamping uneven parts by hand.

Select any assembly on right and add the suffix letters in bold to the part number below and we will fax you details of the assembly items together with prices and dimensions. Ex: UDB-920720-BKSW

CLAMP ASSEMBLY TYPES AVAILABLE	
<b>SNW</b> Spherical Flange Nut & Washer	
<b>FN</b> Flange Nut	
<b>NSWS</b> Nut & Spherical	
<b>HKSW</b> Hand Knob & Spherical Washer Set	
<b>ANSW</b> Acorn Nut & Spherical Washer Set	
<b>BKSW</b> Bar Knob & Spherical Washer Set	
<b>FNSW</b> Flange Nut & Spherical Washer Set	
<b>KK</b> Knurled Knob	
<b>KKSW</b> Knurled Knob & Spherical Washer Set	
<b>QAHKSW</b> Quick Acting Hand Knob & Spherical Washer Set	

DOUBLE END ACORN NUT ASSEMBLY	DOUBLE END HAND KNOB ASSEMBLY	A	B	C	D	E	F	Cap. G
UDB-920420	UDB-920720	5/8	1-1/4	3	3/8-16	1	13/32	1-5/8
UDB-920422	UDB-920722			4				
UDB-920424	UDB-920724			5				
UDB-920426	UDB-920726			6				
UDB-920430	UDB-920730	5/8	1-1/4	4	1/2-13	1	17/32	1-5/8
UDB-920432	UDB-920732			4-1/2				
UDB-920434	UDB-920734			5				
UDB-920436	UDB-920736			5-1/2				
UDB-920438	UDB-920738			6				
UDB-920442	UDB-920742	3/4	1-1/2	4-1/2	5/8-11	1-1/4	21/32	1-3/4
UDB-920444	UDB-920744			5				
UDB-920446	UDB-920746			5-1/2				
UDB-920448	UDB-920748			6				
UDB-920450	UDB-920750	1	1-3/4	6	3/4-10	1-3/4	25/32	2
UDB-920452	UDB-920752			6-1/2				
UDB-920454	UDB-920754			7				
UDB-920456	UDB-920756			7-1/2				

# Instant Single End Clamping Assemblies

## Single End Clamp Assemblies

ALL ASSEMBLIES HAVE SLOTTED HEELS and INCLUDE ALL PARTS SHOWN.

### SINGLE END ACORN NUT

Acorn Nut Clamp Assembly	Hex Nut Clamp Assembly	Center Hand Knob Clamp Assembly	A	B	C	D Thread	E	F	G Travel	H	J Capacity
UDB-920205 UDB-920207	UDB-920005 UDB-920007	UDB-920105 UDB-920107	3/8 ↓	5/8 ↓	2 2-1/2	1/4-20 ↓	15/16 ↓	9/32 ↓	1/2 ↓	1 1-1/8	7/8 ↓
UDB-920210 UDB-920212 UDB-920214	UDB-920010 UDB-920012 UDB-920014	UDB-920110 UDB-920112 UDB-920114	1/2 ↓	1 ↓	2-3/4 3-1/4 3-3/4	5/16-18 ↓	1-1/4 ↓	11/32 ↓	7/16 13/16 1-3/16	1-1/2 ↓	1-1/8 ↓
UDB-920220 UDB-920222 UDB-920224 UDB-920226	UDB-920020 UDB-920022 UDB-920024 UDB-920026	UDB-920120 UDB-920122 UDB-920124 UDB-920126	5/8 ↓	1-1/4 ↓	3 4 5 6	3/8-16 ↓	1-3/8 1-7/8 2-3/8 2-7/8	13/32 ↓	3/4 1 1-1/2 2	1-3/4 2-1/4 2-3/4 3-1/4	1-5/8 ↓
UDB-920230 UDB-920232 UDB-920234 UDB-920236 UDB-920238	UDB-920030 UDB-920032 UDB-920034 UDB-920036 UDB-920038	UDB-920130 UDB-920132 UDB-920134 UDB-920136 UDB-920138	5/8 ↓	1-1/4 ↓	4 4-1/2 5 5-1/2 6	1/2-13 ↓	1-7/8 ↓	17/32 ↓	1 1-1/2 ↓	2-1/4 ↓	1-5/8 ↓
UDB-920242 UDB-920244 UDB-920246 UDB-920248	UDB-920042 UDB-920044 UDB-920046 UDB-920048	UDB-920142 UDB-920144 UDB-920146 UDB-920148	7/8 ↓	1-1/2 ↓	4-1/2 5 5-1/2 6	5/8-11 ↓	2 ↓	21/32 ↓	1 1-1/2 ↓	2-1/2 ↓	1-3/4 ↓
UDB-920250 UDB-920252 UDB-920254 UDB-920256	UDB-920050 UDB-920052 UDB-920054 UDB-920056	UDB-920150 UDB-920152 UDB-920154 UDB-920156	1 ↓	1-3/4 ↓	6 6-1/2 7 7-1/2	3/4-10 ↓	2-5/8 ↓	25/32 ↓	1-3/4 ↓	3-1/4 ↓	2 ↓

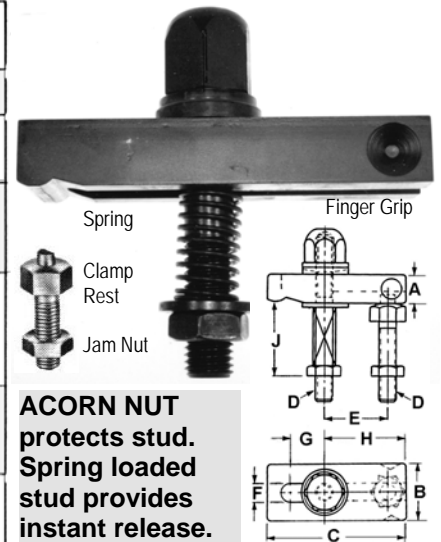

### UNITED ADVANTAGES and FEATURES:

- Finger Grips and Single End Clamp Assemblies

CLAMP ASSEMBLY TYPES AVAILABLE	
<b>SNW</b> Spherical Flange Nut & Washer	
<b>FN</b> Flange Nut	
<b>NSWS</b> Nut & Spherical Washer Set	
<b>HKSWS</b> Hand Knob & Spherical Washer Set	
<b>ANSWS</b> Acorn Nut & Spherical Washer Set	
<b>BKSWS</b> Bar Knob & Spherical Washer Set	
<b>FNSWS</b> Flange Nut & Spherical Washer Set	
<b>KK</b> Knurled Knob	
<b>KKSWS</b> Knurled Knob & Spherical Washer Set	
<b>QAHKSWS</b> Quick Acting Hand Knob & Spherical Washer Set	

- simplify lateral adjustments.
- Cuts machine down time.
- Eliminates tedious tightening of strap clamps one at a time
- All parts except springs, jam nuts and knobs are heat treated material and have black oxide finish.
- Spherical Washers adjust the irregularities between clamp strap and the part being held which assures a rigid hold down.
- Long-life Springs manufactured to QQ-W-470A.
- Individual components are shown in Sections F and G.
- Stable clamping with dependable holding power.
- Fast set-ups.
- Economical and practical.
- Determine specific sizes via dimensional drawings.
- See previous page for more features.

### SINGLE END HEX NUT CLAMPS

HEX NUT is the most economical means of holding with maximum pressure and adjusting for maximum clamping range. Sometimes referred to as Heel Clamp Assembly. Provides visual assurance of thread engagement.

Select any assembly on far left and add the suffix letters in bold to the part number and we will fax you details of the assembly items together with prices and dimensions. Ex: UDB-920005-BKSWS

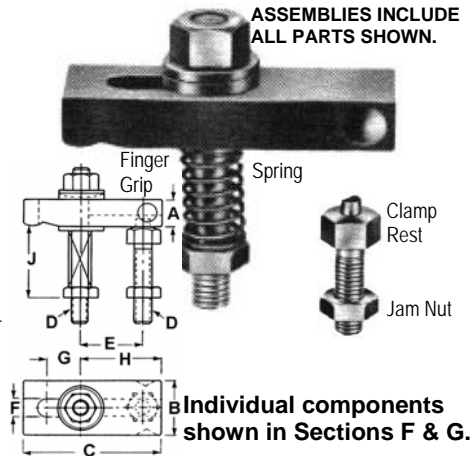

### SINGLE END HAND KNOB CENTER CLAMPS

HAND KNOB is the fastest adjustment style. Does not require a wrench. Spherical Washers permit clamping parts by hand.

Determine specific sizes via individual dimensional drawings and the chart above.

ASSEMBLIES INCLUDE ALL PARTS SHOWN.

