

Leveling and Support

Support from UNITED
is on the Level

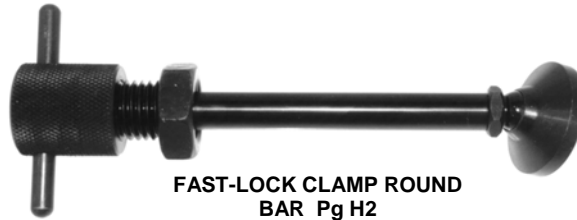

SPRING JACK LOCKS
Pg H10



FAST-LOCK CLAMP ROUND BAR
Pg H2



STEEL SOCKET LEVELING PADS
Pg H12

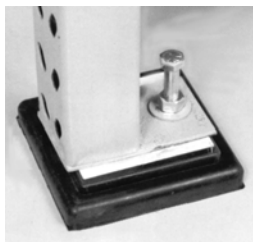

CUSHIONED UNI-PADS
Pg H17



FIXTURE JACKS Pg H18



JIG LEVELING FEET & PADS
Pg H16



SS SOCKET LEVELING PADS
Pg H12



SIDE LEVELING SCREW ASSEMBLY
Pg H15

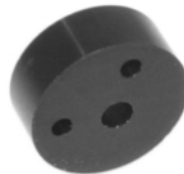

LEVELING LUG
Pg H5

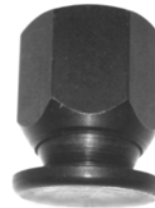

18° SWIVEL PADS
Pg H11



15° TOGGLE PADS
Pg H11



FLAT FOOT JIG SUPPORT FEET
Pg H18

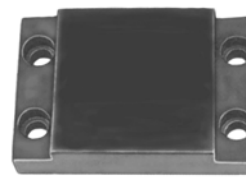

REST PADS Pg H5



THUMB SCREWS
Pg H4



SPHERICAL LEVELING SCREW ASSEMBLY
Pg H4



LEVELING SCREW TUBE NUT ASSEMBLY
Pg H14



LEVELING SCREW NUT ASSEMBLY
Pg H14



STUD SWIVEL LEVELING PADS
Pg H13

Fast-Lock Clamp Round Bar

Round Bar Fast-Lock Clamp

FAST-LOCK CLAMP — ROUND BAR

Got two seconds? . . . For the Fastest Clamp in the West?

LOCKS SECURELY and QUICKLY!

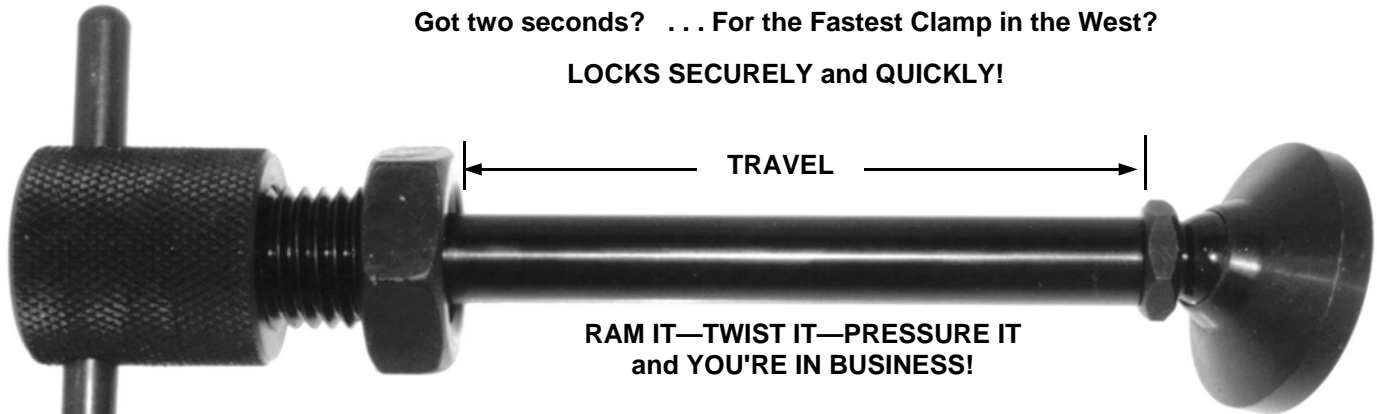

RAM IT—TWIST IT—PRESSURE IT
and YOU'RE IN BUSINESS!

UNITED's Fast-Lock Pressure Screw Locking Clamp adapts to all angles, vertically and horizontally.

This positive, quick ram lock is easily installed. Apply as much pressure to the thread as required. The durable Fast-Lock is also a Fast-Release! The Jam Nut may be loosened and the threaded bushing moved for additional adjustment. The Fast-Lock is available in three lengths for three pad styles. Pads not included.

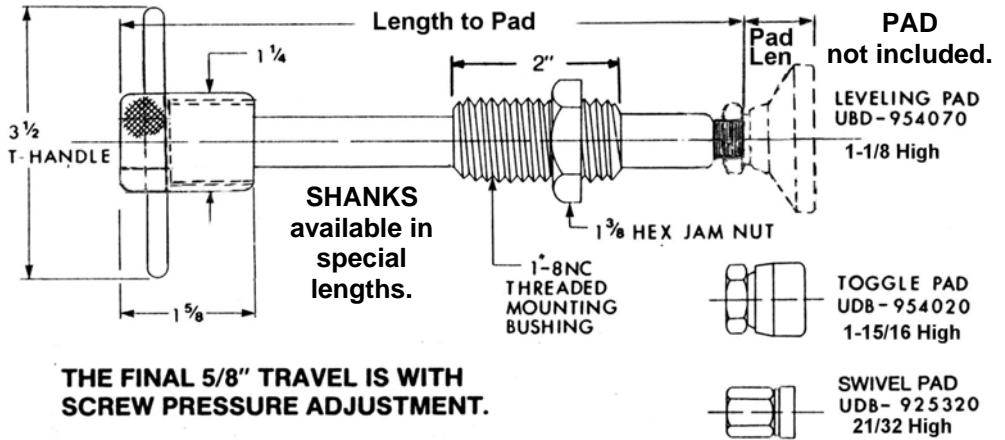

CLAMP PART NO.	SHANK	HOLDING PRESSURE	WEIGHT APPROX.	MOUNTING BUSHING	OVERALL LENGTH	TRAVEL
UDB-954045	5/8	4400	1-1/2 LBS.	1" - 8 NC	6"	2-3/4
UDB-954055	5/8	4400	1-1/2 LBS.	1" - 8 NC	8"	4-3/4
UDB-954065	5/8	4400	1-1/2 LBS.	1" - 8 NC	10"	6-3/4

UNITED FAST-LOCK FITS A VARIETY OF PADS

Purchase Pads separately.

SWIVEL PAD



UDB-925320

TOGGLE PAD



UDB-954020

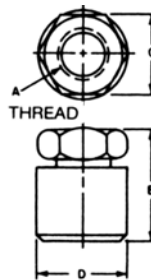

LEVELING PAD



UDB-954070

See Pages H11 and H12
for other
PAD styles and details.

PAD PART NO.	DESCRIPTION	A THREAD	C HEX	B OVERALL LENGTH	D BASE DIA.
UDB-925320	SWIVEL PAD	1/2 - 13	3/4	21/32	11/16
UDB-954020	TOGGLE PAD	1/2 - 13	3/4	1-5/16	7/8
UDB-954070	LEVELING PAD	1/2 - 13	5/8	1-1/8	1-7/8

Fast-Lock Clamping

Fast-Lock Clamps can be opened instantly for work insertion, Ram Fast-Lock forward against work, and turn the handle—you're locked! Releasing action is equally fast. **One quarter turn locks or unlocks.** Place Fast-Lock units at the most advantageous angles. Use the types of pads suited to the contours of the items to be fastened. The problems of the hard-to-hold component are readily solved. **Fast-Lock is designed for high-production service.** They are accurately machined. Pressure bar and threaded collar are made of hardened steel, plated to resist corrosion, provide smooth working surfaces, and give maximum life.

Fast Lock Clamp Square Bar

FAST LOCK CLAMP — SQUARE BAR

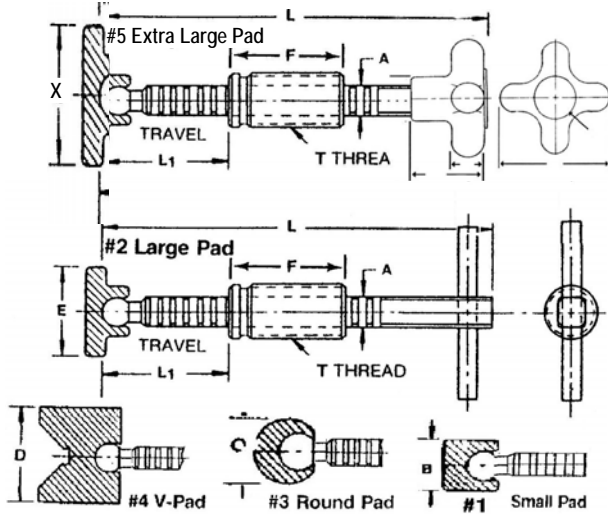

BAR KNOB HANDLE—Add 'K' suffix to P/N



Locks inside threaded Collar Guide.
Advances in one second. Secures in two seconds.

T - HANDLE—Add 'T' suffix to P/N

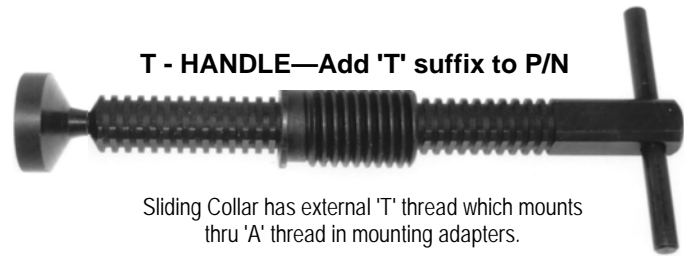

Sliding Collar has external 'T' thread which mounts thru 'A' thread in mounting adapters.

SERIES	FOOT TYPE	A SQ.	B (1) DIA	C (3) DIA	D (4) DIA	E (2) DIA	X (5) DIA	F	T NC-2	L ₁ TRAVEL	L LENGTH					
											4	5	6	8	10	12
STD	1	3/8	3/8				1-1/2	1-3/8	3/4 - 10	1/2" MIN. TRAVEL	UDB-954114	UDB-954115	UDB-954116			
	2										UDB-954124	UDB-954125	UDB-954126			
	3										UDB-954134	UDB-954135	UDB-954136			
	4										UDB-954144	UDB-954145	UDB-954146			
											MAX TRAVEL → 1-9/16	2-9/16	3-9/16			
MED	1	1/2	13/32			3/4	1-3/4	1-11/16	7/8 - 9	9/16 MIN. TRAVEL	UDB-954215F	UDB-954216	UDB-954218	UDB-954210F	UDB-954212	
	2										UDB-954225F	UDB-954226	UDB-954228	UDB-954220F	UDB-954222	
	3										UDB-954235F	UDB-954236	UDB-954238	UDB-954230F	UDB-954232	
	4										UDB-954245	UDB-954246	UDB-954248	UDB-954240	UDB-954242	
											MAX TRAVEL → 2-3/16	3-3/16	5-3/16	7-3/16	9-3/16	
HEAVY DUTY	1	5/8	1/2			15/16	2"	1-11/16	1-1/8 - 7	3/4 MIN. TRAVEL	UDB-954315	UDB-954316	UDB-954318	UDB-954310	UDB-954312	
	2										UDB-954325	UDB-954326	UDB-954328	UDB-954320	UDB-954322	
	3										UDB-954335	UDB-954336	UDB-954338	UDB-954330	UDB-954332	
	4										UDB-954345	UDB-954346	UDB-954348	UDB-954340	UDB-954342	
											MAX TRAVEL → 2-3/16	3-3/16	5-3/16	7-3/16	9-3/16	

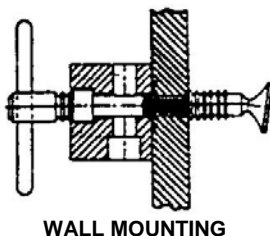
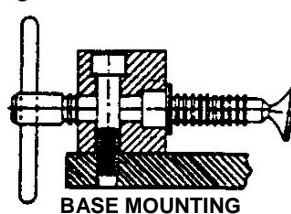
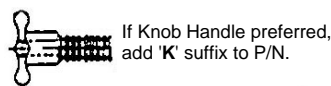
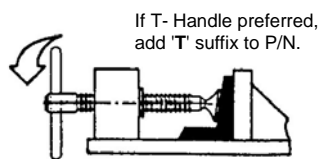
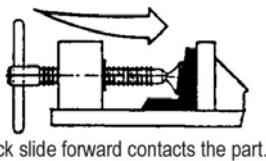
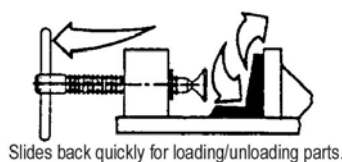

FAST LOCK MOUNTING ADAPTER

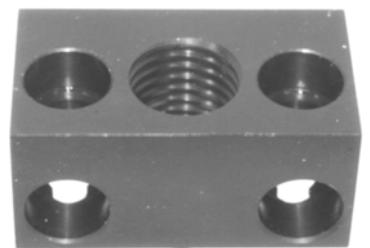
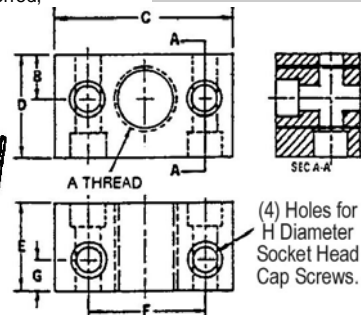

(4) Holes for H Diameter Socket Head Cap Screws. Designed for simplified application of the Fast-Lock to jigs and fixtures.

Bolted, welded or brazed into position, it makes the advantages of quick release available at any point.

PART NO.	A THD	B	C	D	E	F	G	H DIA.
UDB-954101	3/4 - 10	13/16	2-1/8	1-3/8	1-1/4	1-3/8	7/16	5/16
UDB-954201	7/8 - 9	13/16	2-1/2	1-1/2	1-1/4	1-5/8	7/16	3/8
UDB-954301	1-1/8 - 7	1	3-1/8	1-3/4	1-1/2	2-1/8	1/2	1/2

Hex Head & Spherical Leveling Screws

Precision Leveling Accessories

HEX HEAD LEVELING SCREWS

Drilled to reduce weight. Easy to adjust.

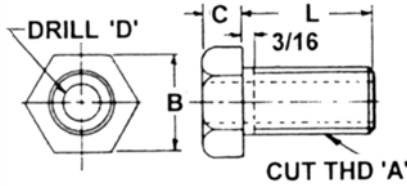
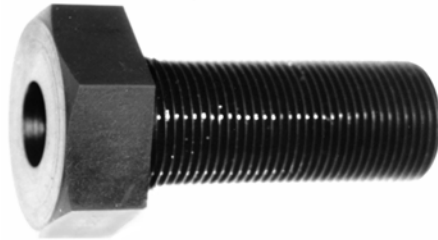

Conforms to UT-7202

HEAT TREATED — BLACK OXIDE FINISH

HEX SCREW PART NO.	A THD NF-2	B	C	D +.015/-000	L
UDB-720251	5/8-18	15/16	3/8	3/8	1
UDB-720252	5/8-18	15/16	3/8	3/8	2
UDB-720261	3/4 - 16	1-1/8	15/32	3/8	1
UDB-720262	3/4 - 16	1-1/8	15/32	3/8	2
UDB-720263	3/4 - 16	1-1/8	15/32	3/8	3
UDB-720281	1 - 14	1-1/2	19/32	5/8	1
UDB-720282	1 - 14	1-1/2	19/32	5/8	2
UDB-720283	1 - 14	1-1/2	19/32	5/8	3
UDB-720302	1-1/4 - 12	1-7/8	3/4	3/4	2
UDB-720303	1-1/4 - 12	1-7/8	3/4	3/4	3

SPHERICAL LEVELING SCREW ASSEMBLY

SPHERICAL LEVELING SCREW

ADD 'S' TO PART NO. FOR SET WITH SOCKET

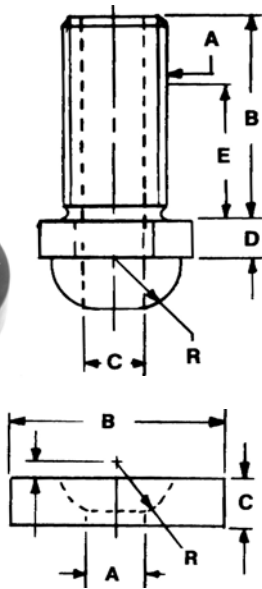

SPHERICAL LEVELING SCREW SOCKET

Conforms to UT-7201

TOUGH — DURABLE — HEAT TREATED — BLACK OXIDE FINISH

SPH. SCREW PART NO.	A THD CLASS 2	B	C	D	E*	R	SOCKET NUMBER
UDB-721001	5/8-18	1-1/2	3/8	3/8	1	3/8	UDB-721002
UDB-721003	7/8 - 14	1	1/2	3/8	5/8	9/16	UDB-721004
UDB-721005	7/8 - 14	2	1/2	3/8	1-1/4	9/16	UDB-721004
UDB-721007	7/8 - 14	3	1/2	3/8	2	9/16	UDB-721004
UDB-721009	1 - 14	1	5/8	3/8	5/8	5/8	UDB-721006
UDB-721011	1 - 14	2	5/8	3/8	1-1/4	5/8	UDB-721006
UDB-721013	1 - 14	3	21/32	3/8	2	5/8	UDB-721006
UDB-721101	1 - 14	4	21/32	3/8	2-1/2	5/8	UDB-721006
UDB-721103	1 - 14	6	21/32	3/8	4	5/8	UDB-721006
UDB-721105	1-1/4 - 12	4	21/32	1/2	2-1/2	7/8	UDB-721100
UDB-721107	1-1/4 - 12	6	21/32	1/2	4	7/8	UDB-721100
UDB-721109	1-1/4 - 12	8	21/32	1/2	5	7/8	UDB-721100
UDB-721111	1-1/2 - 12	4	21/32	3/4	2-1/2	1	UDB-721102
UDB-721113	1-1/2 - 12	6	21/32	3/4	4	1	UDB-721102
UDB-721115	1-1/2 - 12	8	21/32	3/4	5	1	UDB-721102

* E = MAXIMUM SAFE PROTRUSION

The Spherical Leveling Screw and Socket are generally used in Sets.

SOCKET PART NO.	A	B	C	R
UDB-721002	13/32	1-1/2	3/8	3/8
UDB-721004	17/32	2	1/2	9/16
UDB-721006	21/32	2-1/4	1/2	5/8
UDB-721100	21/32	2-3/4	3/4	7/8
UDB-721102	21/32	3-1/4	1	1

THUMB SCREWS

MALLEABLE STEEL — COLD HEADED — ZINC PLATED

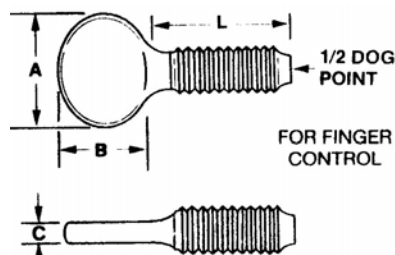

Conforms to UT-7117

THM. SCREW PART NO.	THD	A	B	C	L
UDB-717316	10 - 24	9/16	3/8	3/32	1
UDB-717324	10 - 24	9/16	3/8	3/32	1-1/2
UDB-717416	1/4 - 20	13/16	1/2	9/64	1
UDB-717424	1/4 - 20	13/16	1/2	9/64	1-1/2
UDB-717432	1/4 - 20	13/16	1/2	9/64	2
UDB-717440	1/4 - 20	13/16	1/2	9/64	2-1/2
UDB-717448	1/4 - 20	13/16	1/2	3/32	3
UDB-717516	5/16 - 18	15/16	5/8	5/32	1
UDB-717524	5/16 - 18	15/16	5/8	5/32	1-1/2
UDB-717548	5/16 - 18	15/16	5/8	5/32	3
UDB-717616	3/8 - 16	1-1/16	11/16	13/64	1
UDB-717648	3/8 - 16	1-1/16	11/16	13/64	3

We Believe Quality Means the Same to You As It Does to UNITED.

Leveling Accessories

**Eccentric Leveling Lugs,
Jig Legs & Rest Pads**

LEVELING LUG COVER

UDB-653040



BLACK OXIDE FINISH

INSTALLED
TOP VIEW

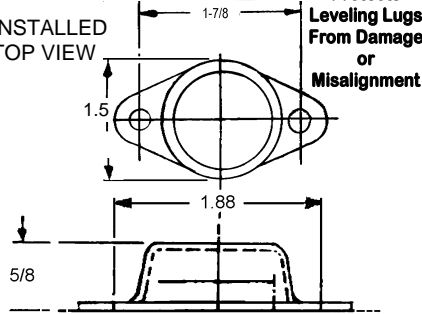

Protects
Leveling Lugs
From Damage
or
Misalignment

REF STD-132B, T-53029, CTS-640B, UT-7210-2

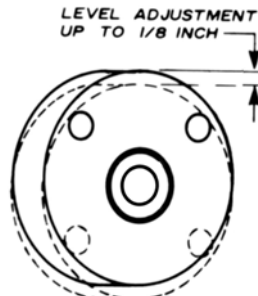

CONFORMS TO UT-7210

To use *UNITED's* Eccentric Leveling Lugs, simply rotate until the desired level is secured then drill and dowel in

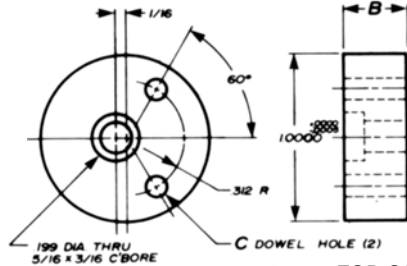

ECCENTRIC LEVELING LUG

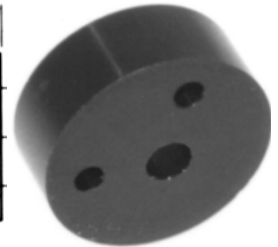

FOR SOCKET HEAD CAP SCREW

LEVELING LUGS PART NO.	B	C DIAMETER	MATERIAL CONDITION
UDB-653029	1/4	#31 (.1200)	SOFT
UDB-653031	1/4	1/8 REAMED	HARD
UDB-653033	3/8	#31 (.1200)	SOFT
UDB-653035	3/8	1/8 REAMED	HARD

These Legs raise the jig, preventing it from resting on chips or dirt that may accumulate on the table.

Heat Treated Steel — Black Oxide Finish

JIG LEGS PART NO.	A	B +.000 -.001	C THREAD	D	E	F	G	H
UDB-947020	1	.625	1/2-13	9/16	9/16	1/4	7/8	13/32
UDB-947021	2							
UDB-947022	3							
UDB-947023	4							
UDB-947024	6							
UDB-947025	2	.750	5/8-11	11/16	11/16	5/16	1-1/16	1/2
UDB-947030	3							
UDB-947035	4							
UDB-947040	6							
UDB-947045	2							
UDB-947050	3							
UDB-947055	4							
UDB-947060	8							

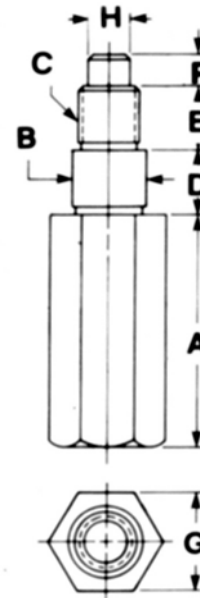

JIG LEGS

REST PADS REPLACE REST BUTTONS. Rest Pads support large work pieces in heavy duty applications where rest buttons are inadequate. *UNITED* Rest Pads are ready to install.

3/8 Socket Head Cap Screw

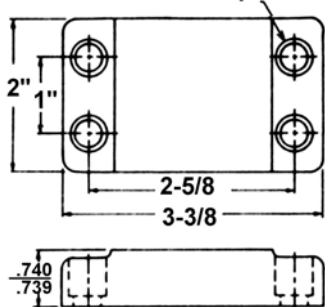

**LARGE PAD
UDB-546560**

3/8 Socket Head
Cap Screws

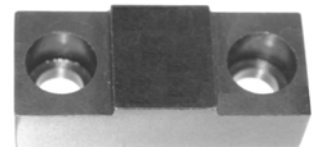
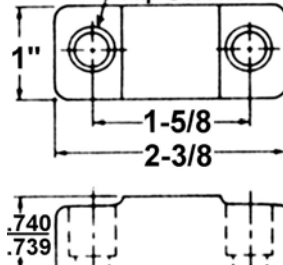

**SMALL PAD
UDB-546550**

REST PADS

Precision Ground
Heat Treated
Black Oxide